

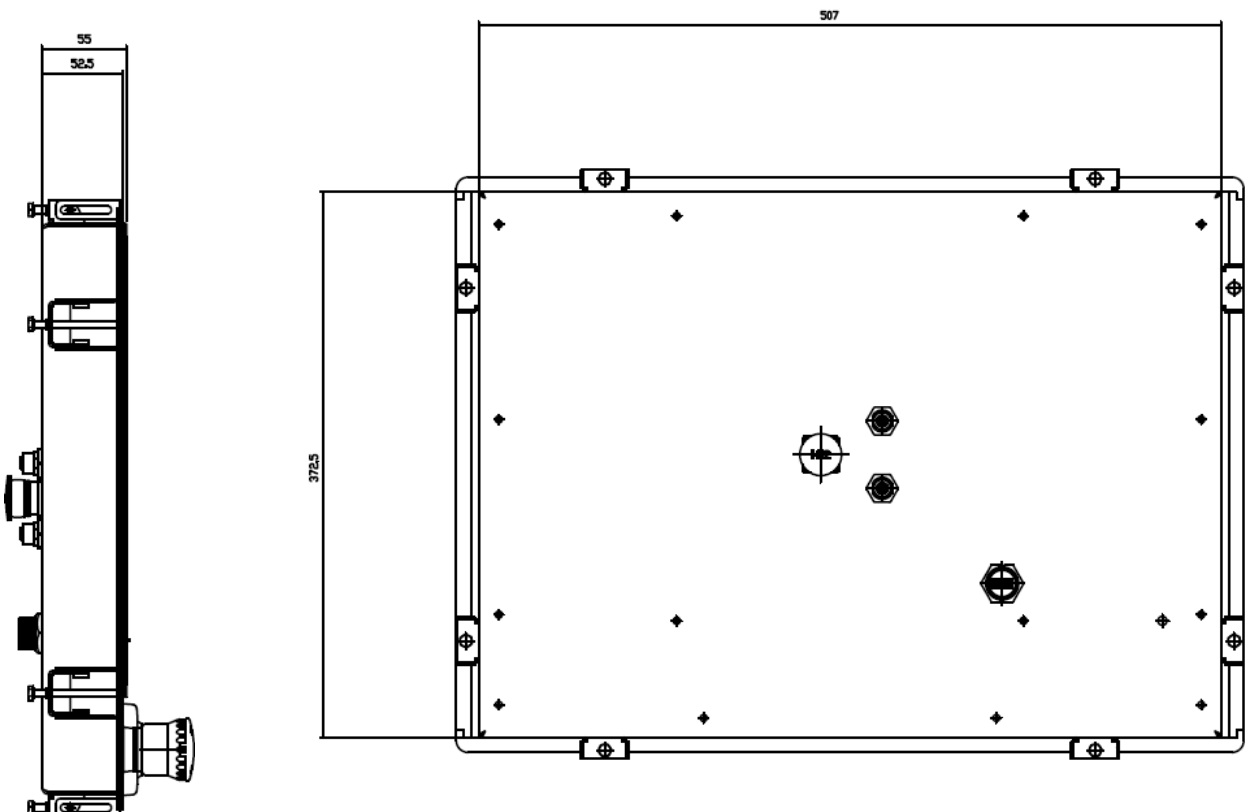

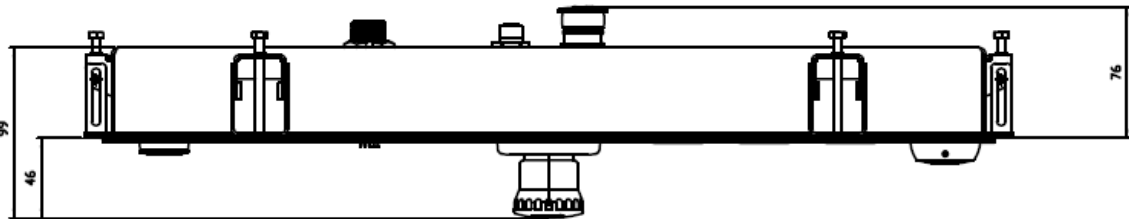

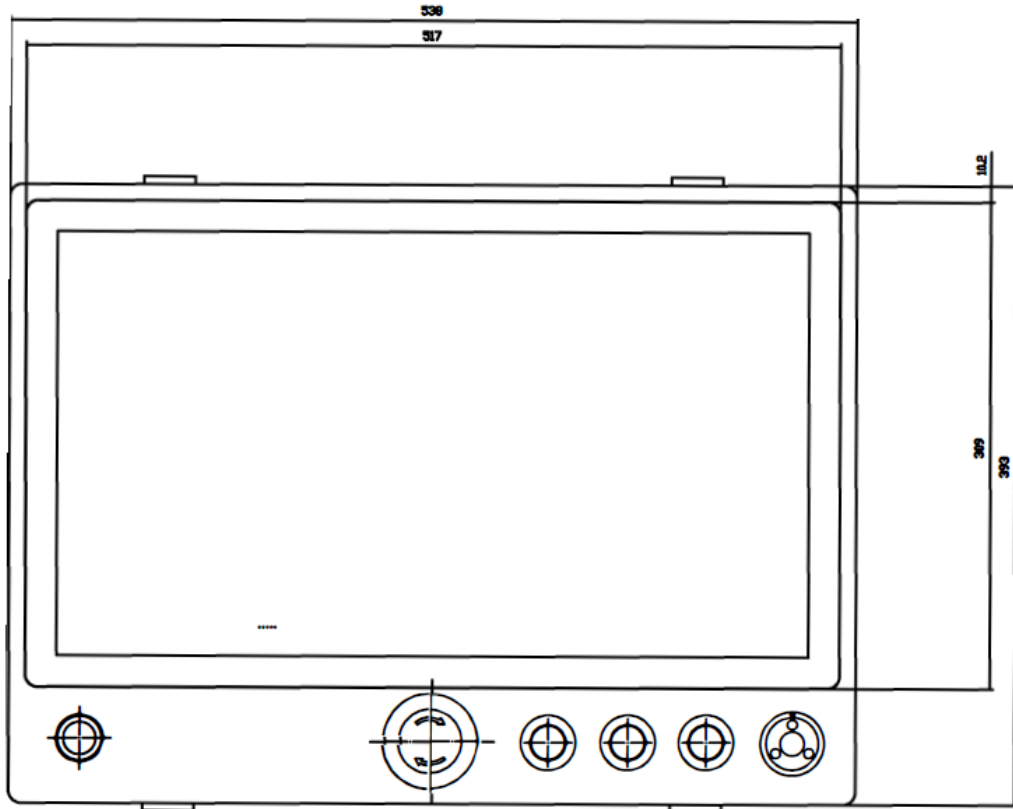

# 6. Installation



# 7. Wiring diagram for machine wiring

*Image for indicative purposes only:  
The wiring diagram is variable depending on the wiring.*

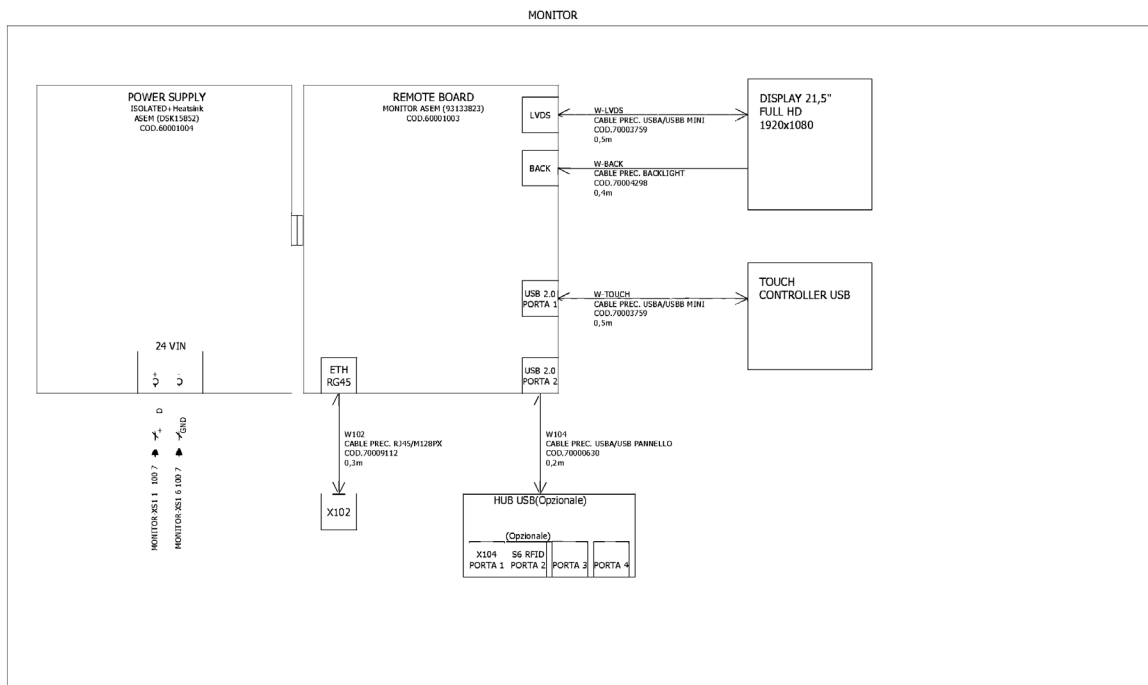
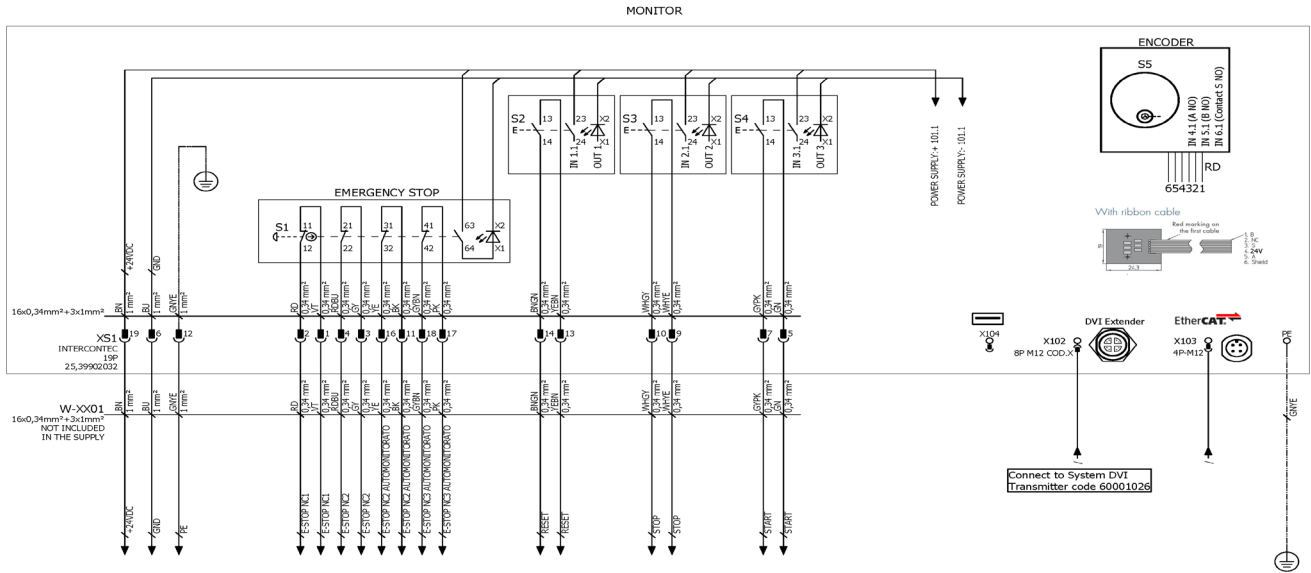

## 8. Waste Directive

Information to users pursuant to Decree Legislative Decree no. 49 of March 14, 2014 "Implementation of Directive 2012/19/EU on waste electrical and electronic equipment (WEEE).

Decree 25 July 2014 of the Ministry of the Environment, on "Implementation of the European Commission Delegated Directives **2014/69/EU, 2014/70/EU, 2014/71/EU, 2014/72/EU, 2014/73/EU, 2014/74/EU, 2014/75/EU, 2014/76/EU** of 13 March 2014 amending Decree 4 March 2014 No.



27 on the restriction of certain hazardous substances in electrical and electronic equipment (RoHS)". The crossed-out wheellie bin symbol shown on the equipment or its packaging indicates that this product, at the end of its useful life, must be collected separately from other waste. The separate collection of this end-of-life equipment is organized and managed by the manufacturer. Users who wish to discard this equipment should contact the manufacturer and follow the manufacturer's system for waste disposal of end-of-life equipment. The proper separate collection for subsequent recycling, treatment and environmentally compatible disposal of the equipment contributes to avoiding possible negative effects on the environment and health and promotes the reuse and/or recycling of the materials from which the equipment is made. Illegal disposal of the product by the owner involves the application of administrative sanctions provided for by current legislation.